

2016-2018 ICON LINK Valley ICON Panels

Intro 1 – Page 2 – Introduction

Section 1 – Page 3 – Unit Mounting

Section 2 – Pages 4-9 – Unit Wiring

Section 3 – Page 10 – Valley ICON Panel Configuration

Section 4 – Page 11 – ICON LINK Configuration

Section 5 – Page 11 – ICON LINK LED's

Section 6 – Page 12-13 – Specs and Warranty

Introduction

The all new 2016 ICON LINK unit mounts inside the control panel door of Valley ICON digital irrigation control panels. The ICON LINK unit communicates directly with the digital control panel to monitor/control the irrigation system remotely via the Wagnet.net website or Wagnet Mobile App. ICON LINK unit uses a simple serial cable to connect the unit to the Valley ICON Control panel, plus only has a few simple wire connections to give the unit power.

This wiring manual includes an overview of the major components of the ICON LINK unit, and provides detailed wiring instructions of the unit and accessories. See below for overview, and the following pages for mounting and wiring.

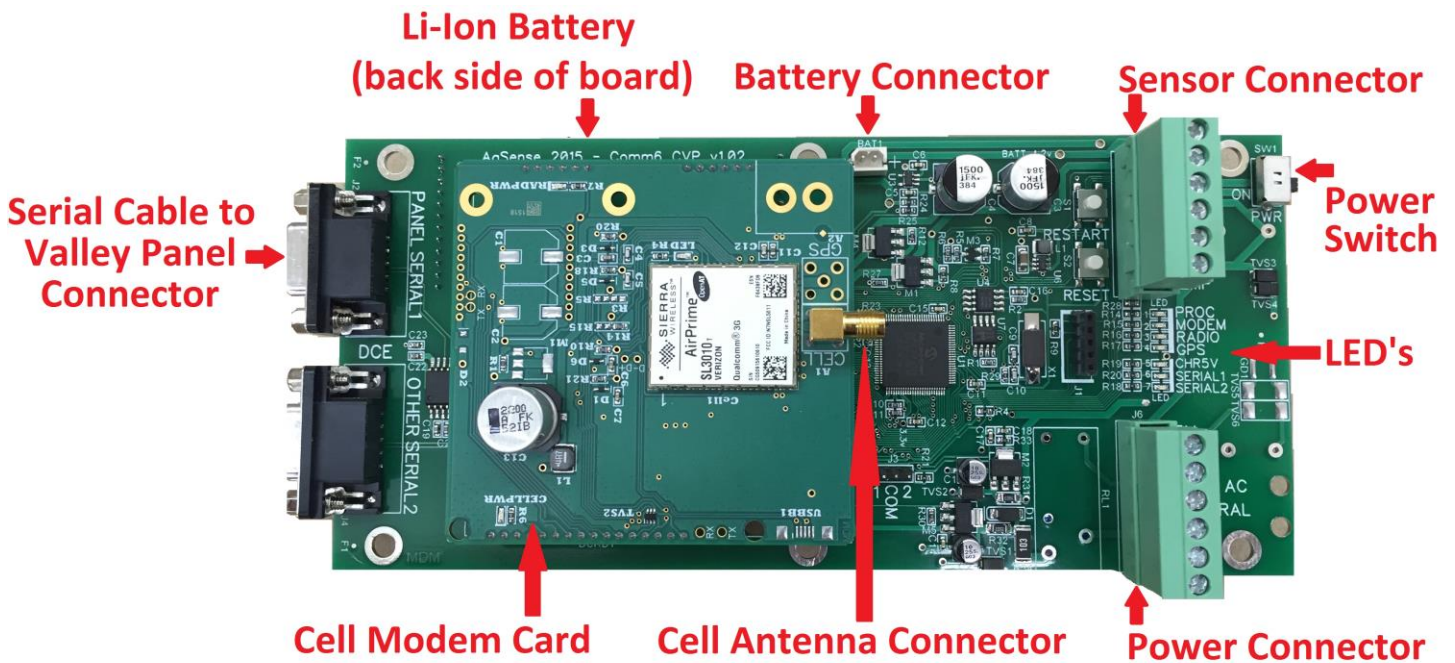

ICON LINK Mounting

Turn off the main disconnect on the Valley ICON panel, and open the door fully. Using the three screws and nuts provided in the install kit, mount the ICON LINK to the inside of the Valley control panel door as shown below.

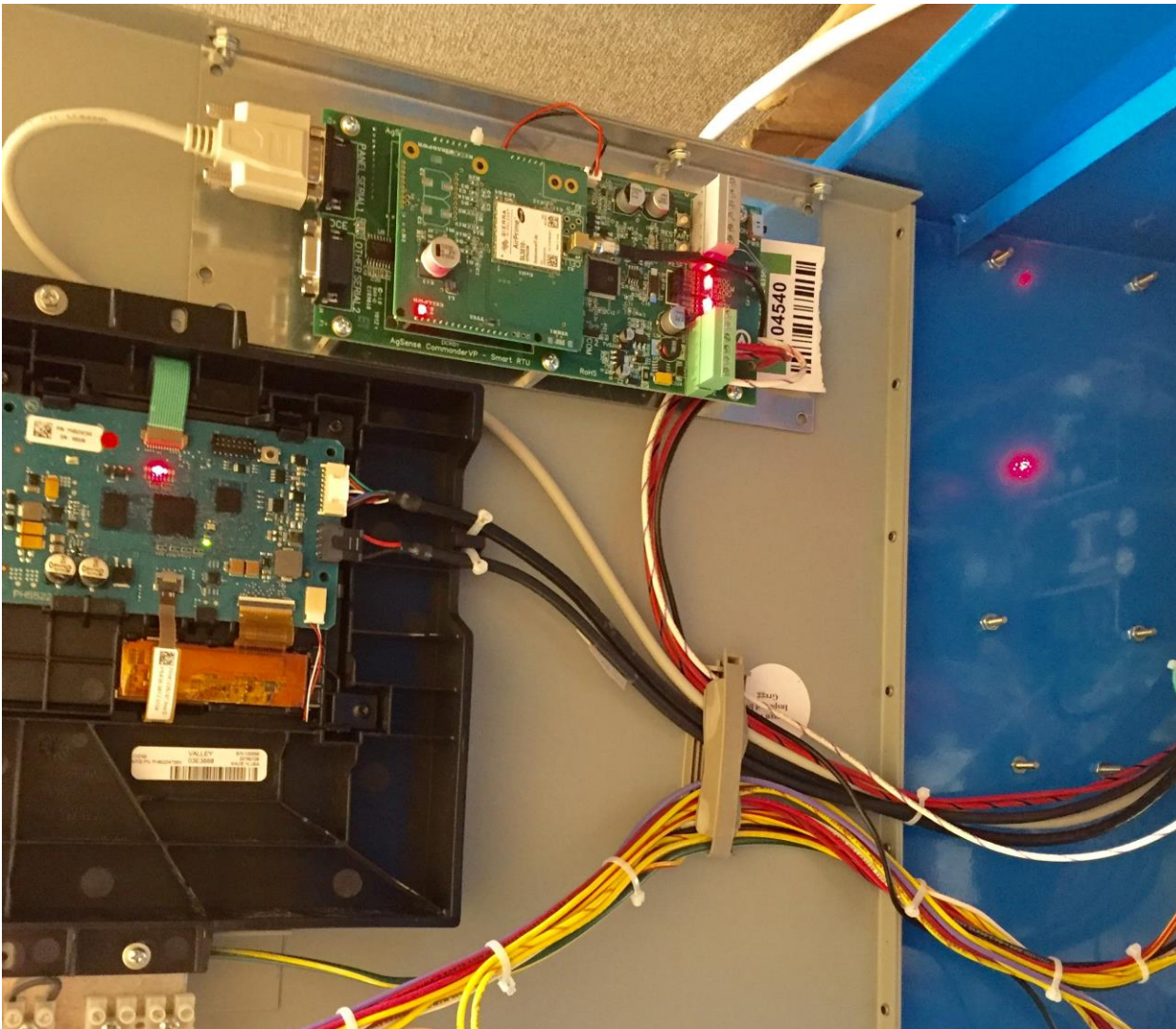

ICON LINK Wiring

ICON LINK Serial Cable Connection

Connect the included Serial Cable to the ICON LINK “Panel Serial 1” port as shown in the photo below.

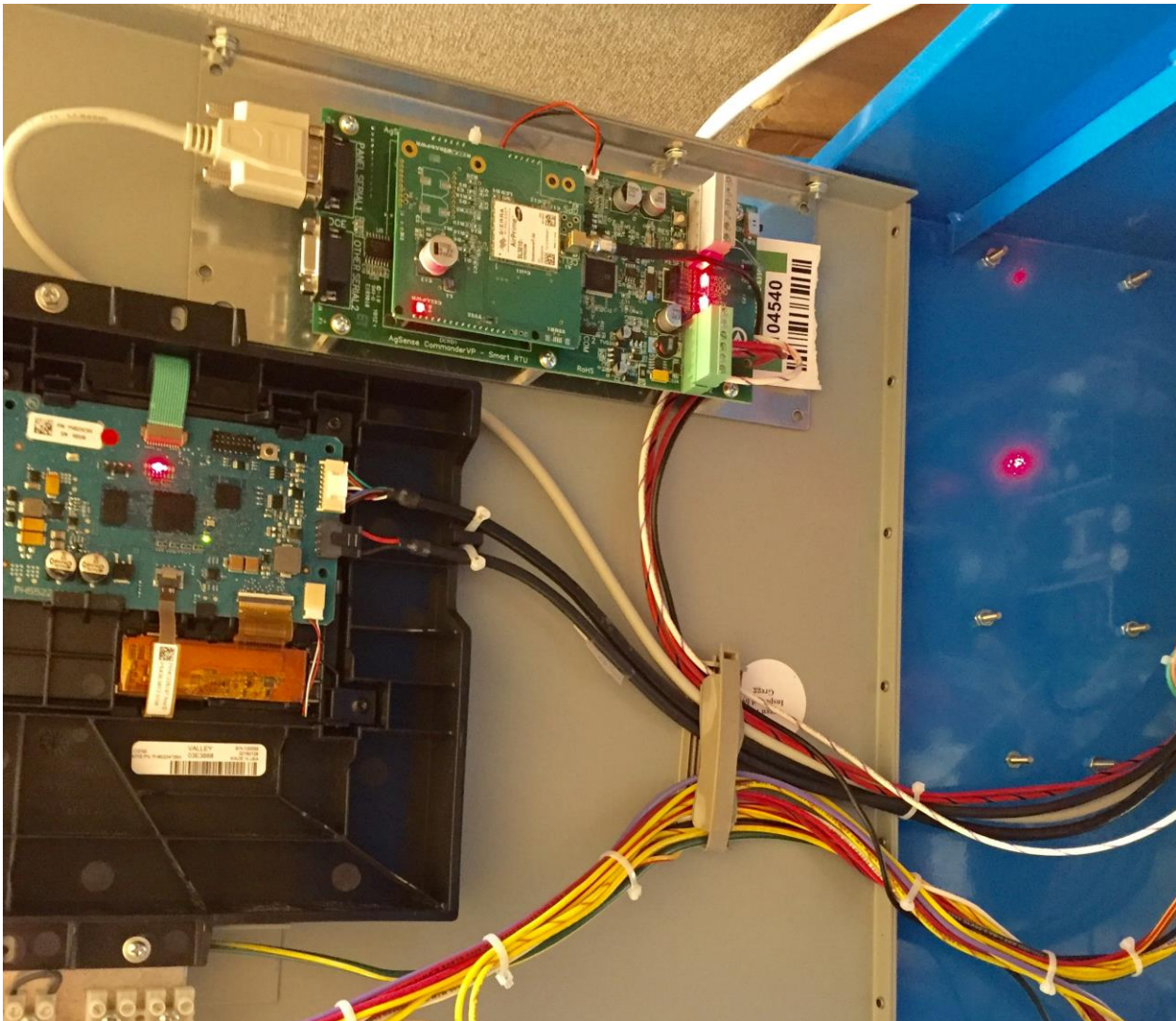

Connect the opposite end of the Serial Cable to the Valley panel 9 pin Serial Port (J12) on the SRB Relay board in the panel as shown in the photo below.



ICON LINK Power Supply and Wire Connections

1. Attach the magnetic mount cellular antenna onto the top of the Valley panel and route the antenna wire behind the panel and into the bottom of the panel using the included cable grip.
2. Then, route the Antenna cable plus the Red, and Red/Black wires next to the existing door cables/wires and through the existing wire holders on the Valley panel door up to the ICON LINK and plug in the wire harness to the ICON LINK as shown in the photo below.

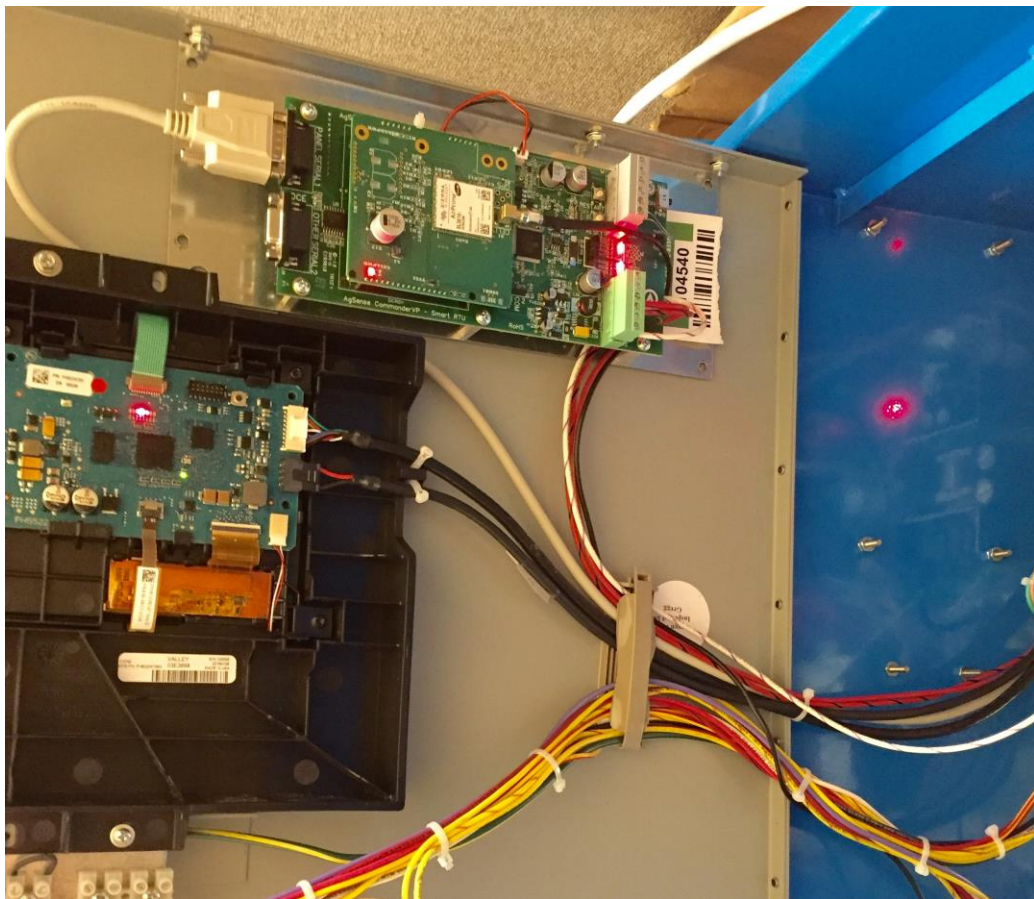

3. Then screw the antenna cable end onto the cell modem card as shown in the photo below (gold screw connection)

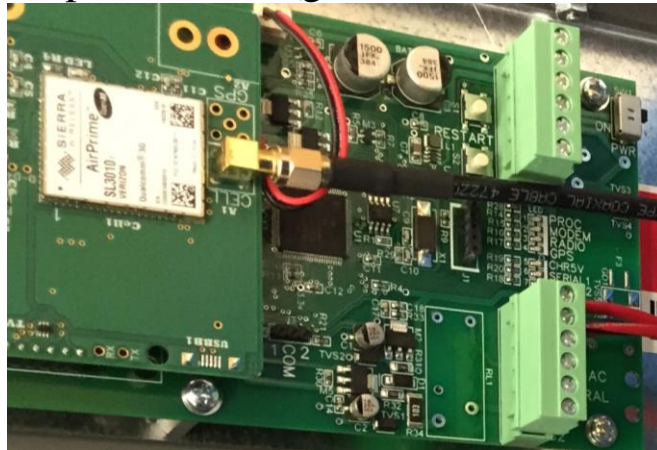

4. Use the included zip-ties to secure the wires neatly to the existing Valley wires as needed.

5. Attach the RED (+12v) and RED/BLACK (GND) wires to the SRB relay board J7 in the Valley panel as shown below.

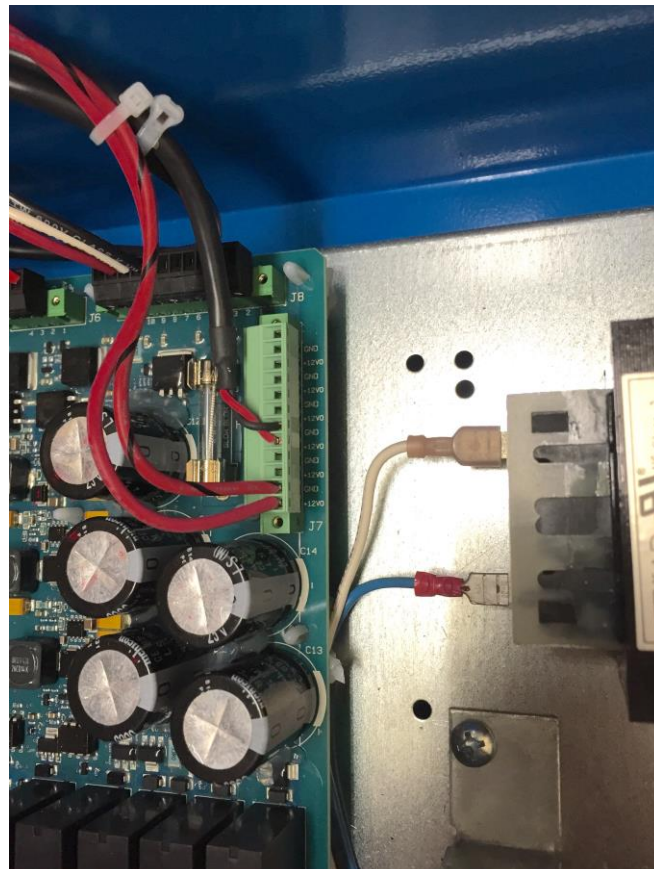

ICON LINK THEFT WIRING

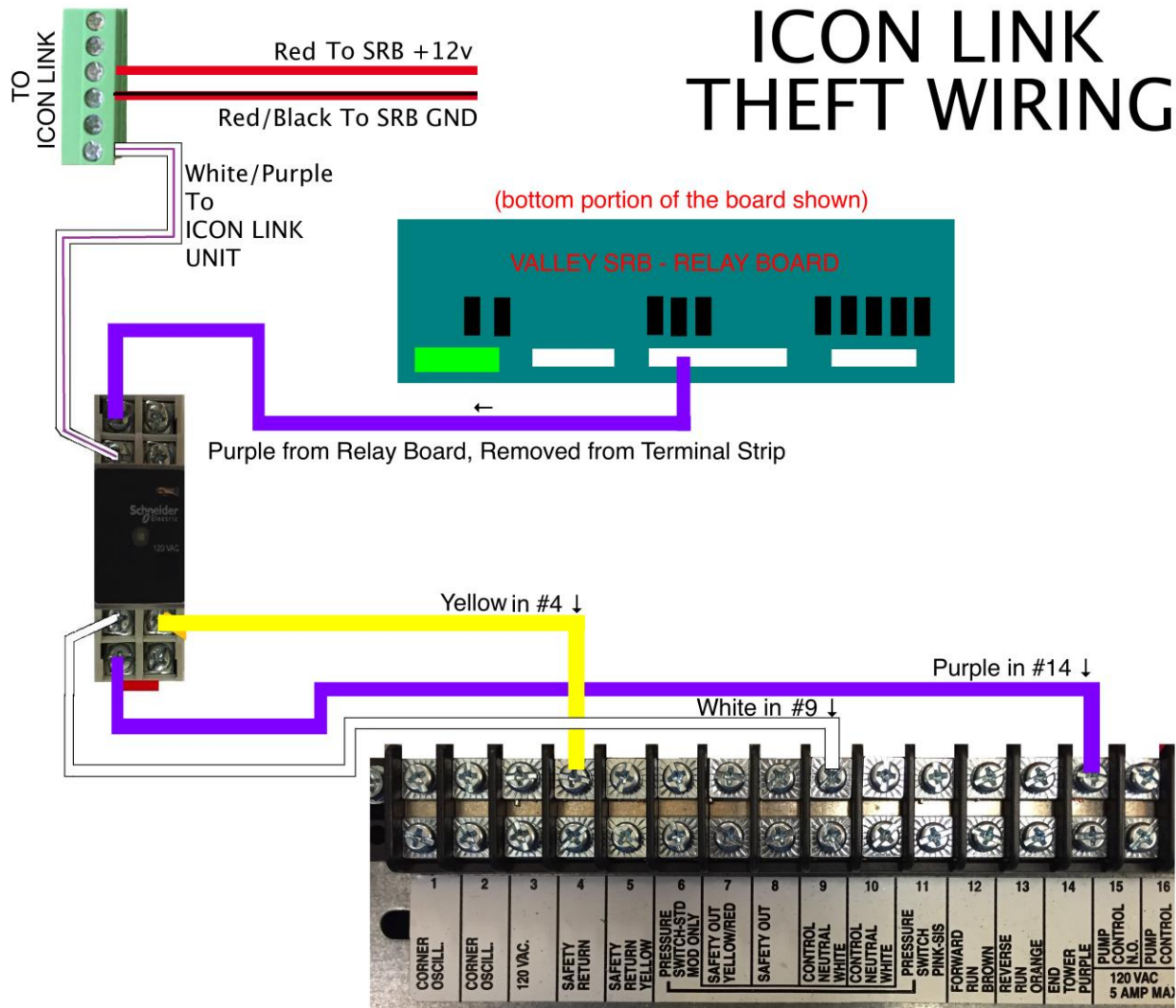

6. After all wires are attached and secured, make sure the power switch on the ICON LINK is turned on, and then close the Valley panel door and turn the main disconnect switch on.

7. If your ICON Link came with the Theft Monitor as a separate kit, please wire it in as shown above. After wiring in the Theft Monitor kit, the dealer must call AgSense to enable the feature. The theft monitor will not work without completing this step.

8. After completing Step 7, and setting up a phone number/s in the Alerts config, test the theft monitor feature with the pivot off, by removing the speed wire from a tower box terminal strip for a couple minutes, after you receive the alert, you can place the wire back into the tower box terminal strip.

Valley ICON Panel Configuration

The Valley ICON panel will already be set to the correct configuration from the factory. If needed, you can check the following items in the Valley panel menu to confirm that the following items are set correctly:

Constants Menu:

1. RTU ID – Make sure the RTU ID = 0
2. Com Port – Make sure the 9 pin Com Port settings are the following: Protocol = Valley VCP, and Baud Rate = 9600.

ICON LINK unit Configuration

For best results, log on to www.wagnet.net and enter your username and password. Click on the unit you wish to configure, and click on the “config” tab. Make sure all items are entered correctly and click on “Save Settings”. Then scroll down to the bottom and use the map to find your field and click once on top of the center point of your irrigation system and then again click “Save Settings” . This will then correctly display your field image on the main unit view on wagnet and on the mobile app.

ICON LINK LED’s

PROC LED - This LED blinks at a steady rate to show the processor is working normally.

MODEM LED – This LED blinks when the cell modem is attempting to connect to a cell tower, and is on steady when the unit has a good cell connection.

RADIO LED – Not used unless unit has a radio installed – This LED blinks when the radio is attempting to connect to another unit with a radio installed, and is on steady when the unit has a good radio connection.

GPS LED – This LED is not used at this time.

CHR5V LED – This light is on steady when the Valley panel main disconnect is turned on.

SERIAL 1– This LED flashes when the ICON LINK successfully communicates with the Valley panel.

Power Requirements for the ICON LINK unit:

12v DC: 1.0A MAX
0.05A - 0.25A during normal operation

Warranty Information:

All warranty service provided by the AgSense service center, or an authorized technician.

**Warranty repairs require a Return Merchandise Authorization Number (RMA);
Have your dealer contact AgSense to obtain this RMA number.**

For the Period of :	AgSense will:
60 Days	Money back Guarantee if not satisfied with product.
2 Years	Repair on any unit that fails due to defect in materials or workmanship. AgSense labor and parts would be provided free of charge during the warranty period. (This does not include dealer labor.)

What is not covered:

- Service trips to your home to teach you how to use the product.
- Improper installation, delivery or maintenance. If you have an installation problem contact your dealer or installer.
- Failure of product resulting from modification to product or due to unreasonable failure to provide reasonable and necessary maintenance.
- Labor necessary to move device from one location to another.
- Improper installation of battery.
- Failure due to corrosion or water damage.
 - Units installed in direct contact with sprinklers require a tower box or other watertight protection.
- Damage to the product caused by improper power supply voltage, accident, fire, floods or acts of God.
- Damage caused after delivery.

Exclusion of implied warranties – Your sole and exclusive remedy is product repair as provided in this Limited Warranty. Any implied warranties, including the implied warranties of merchantability or fitness for a particular purpose, are limited to two years or the shortest period allowed by law.

This warranty is extended to the original purchaser and any succeeding owner for the products purchased for use within the USA.

Some states do not allow the exclusion or limitation of incidental or consequential damages. This warranty gives you specific legal rights, and you may also have the other rights which vary from state to state. To know what your legal rights are, consult your local or state consumer affairs office or your state's Attorney General.

DISCLAIMER: The use of Field Commander/Crop Link/Aqua Trac/CommanderVP/Icon Link shall not be utilized by customer as a substitute for the Customer's personal observation of the manner in which Customer's irrigation equipment is functioning. AgSense specifically advises Customer that this product is designed to enhance Customer's ability to control existing irrigation equipment and to provide the Customer with additional information about existing irrigation equipment. Field Commander/Crop Link/Aqua Trac relies upon GPS, Satellite and Internet technology which not always functions properly, accordingly, AgSense disclaims any and all responsibility for the reliability of this technology. Customer acknowledges that AgSense does not have the ability to control the reliability of GPS, Satellite and Internet Technology. AgSense specifically disclaims any and all liability for Customer's failure to personally determine whether or not the irrigation equipment that belongs to Customer is functioning properly. AgSense, its agents, members or officers will not be liable for Customer's loss of profits, business interruption, or any other type of consequential damages arising because of the failure to Customer's equipment, GPS, Satellite or Internet to function properly.

CUSTOMER'S RESPONSIBILITIES: Customer agrees to keep the irrigation equipment upon which Field Commander/Crop Link/Aqua Trac/CommanderVP/Icon Link is installed in good repair and maintenance. Customer acknowledges the importance of and agrees to keep all safety devices which came with Customer's irrigation equipment in working order. Customer agrees to keep an end field stop and barricades in place to prevent damage to the irrigation equipment in the event that Field Commander/Crop Link/Aqua Trac/CommanderVP malfunctions. Customer agrees that Field Commander/Crop Link/Aqua Trac/CommanderVP cannot solely replace the personal monitoring of the operation of irrigation equipment.

REMEDY: Customer acknowledges that Field Commander/Crop Link/Aqua Trac/Icon Link/CommanderVP's sole obligation and Customer's exclusive remedy in the event of any material and continuing nonconformity, defect, or error in the information service shall be to take reasonable corrective actions upon discovery of the problem.